

# MAGIKIST X-SERIES

TRIPLEX CERAMIC PLUNGER PUMPS

## OPERATING MANUAL

MODELS X8 • X10 • X20

### IMPORTANT OPERATING CONDITIONS

Failure to comply with any of these conditions invalidates the warranty.

**Lubrication** - Prior to initial operation ensure that the oil level is to the halfway mark of the oil gauge window. Do not overfill. Use only Magikist high pressure pump oil or equivalent ISO 220 turbine or circulating oil. Do **not** use automotive, transmission, or hydraulic oils, or brake fluid. Change crankcase oil after first 50 hours of operation, after which change oil at regular intervals of 500 hours or less depending on operating conditions. Each plunger has an foam oiler that is accessible through the plunger cover. Oil each foam oiler weekly.

**RPM and Pressure** - Pump operation must not exceed rated pressure, volume, or RPM. Magikist pumps are normally supplied with a pressure regulator valve which **must** remain installed in the discharge of the system and set not higher than the rated pump pressure. This or a similar pressure relief valve **must** remain installed in the discharge of the system.

**Acids, Alkalies, or Abrasive Fluids** - Consult factory before using pumps with any of these fluids.

**Freezing Conditions** - Pump must be protected from freezing conditions.

### STANDARD CONFIGURATIONS

The X series pumps are a positive displacement type of pump where the delivery is directly proportional to the rotational speed of the pump, regardless of the pressure. The table below shows the recommended standard configurations for the X series pumps.

Pump RPM and output in gallons per minute (GPM) are based on a drive motor speed of 1725 RPM. Pump RPM and GPM output are approximate values due to variations in pulleys, belts and motors between manufacturers and a  $\pm 5\%$  pump output tolerance.

Model Number	GPM	PSI	Pump RPM	Pump Pulley Diameter	Motor Pulley Diameter	Electrical Horsepower Required	Spray Tip Number
X8	2.2	600	485	8"	2-1/4"	1.0	--06
	2.2	1000	485	8"	2-1/4"	1.5	--04
X10	4.1	1000	530	9"	2-3/4"	2.9	--08
X20	3.2	1500	700	9"	3-3/4"	3.0	--05
	3.2	2000	700	9"	3-3/4"	4.4	--04

Consult factory for requirements other than those shown.

For applications using gasoline engines, horsepower requirements are, as a rule of thumb, more than twice that of the electrical horsepower requirements. Consult factory for recommendations.

---

# INSTALLATION INSTRUCTIONS

---

## LUBRICATION

See section under Important Operating Conditions.

## MOTOR SIZE & PULLEY SELECTION

Ensure that the motor meets or exceeds the horsepower required as stipulated in the table under Standard Configurations . The proper size pulley should also be installed on the motor as shown in the same table under Standard Configurations .

## MOUNTING THE PUMP

The pump should be mounted on a rigid horizontal base. Ensure that pulleys are aligned and that the correct belts are used. Belts must be tight enough so that there is no belt slippage, but should not be excessively tight as this places unnecessary strain on the crankshaft bearings.

## INLET PLUMBING

The inlet plumbing should be sized for the flow rate of the pump, at least the same diameter as the inlet to the manifold, although preferably one size larger. There should be no unnecessary restrictions in the inlet plumbing. Length should be kept to a minimum as should the number of elbows and joints. Restrictions in the inlet plumbing may cause cavitation, resulting in severe damage.

Inlet holding tanks must be of adequate size to accommodate the input requirements of the pump. Adequate baffling in the tank should be provided to eliminate air bubbles and turbulence.

An inlet strainer of twice the rated capacity of the pump should be installed in the inlet line. Inspect the inlet strainer frequently to ensure that there are no breaks in the screen and that it is free of particles which might restrict flow. Foreign material entering the pump can easily create problems with your pump or other components in the system.

The inlet port of the pump located near the top of the manifold is a 1/2" FNPT port from which extends a 1/2" long nipple. Teflon tape should be used to seal all joints to ensure that they are airtight.

## INLET PRESSURE

Excessive pressure on the inlet line places increased stress on inlet seals. **MAXIMUM INLET PRESSURE IS 30 PSI.** Installation of the appropriate pressure reducing valve in the inlet line is required to avoid excessive pressures. If desired a pressure gauge may be mounted as close to the pump inlet as possible in order to monitor inlet pressure. Use of excessive inlet pressure will void the warranty.

If pumps are operated at temperatures in excess of 140°F, it is important to insure a positive head to the pump to prevent cavitation.

## DISCHARGE PLUMBING

The discharge plumbing from the pump should be properly sized to the flow rate to prevent line pressure loss.

There are two 3/8" FNPT pressure outlets, one on each side of the manifold. As with inlet plumbing, teflon tape should be used on all joints for proper sealing. High pressure connections to the pump should be made with high pressure hose and not rigid pipe so as to prevent vibrations from damaging the pump and piping.

Magikist X series pumps are normally supplied with both a pressure gauge and a pressure regulator valve. The pressure regulator valve **must** remain in the discharge line and set not higher than the rated pressure in order to prevent over-pressure in the event the discharge or downstream plumbing becomes plugged or is turned off. This or a similar pressure relief valve **must** remain installed in the discharge of the system otherwise personal injury or damage to the pump system may result.

---

---

## HELPFUL INFORMATION

---

### LOW OR HIGH PRESSURE READINGS

Pressure readings that differ from that rated for your pump do **not** necessarily indicate a pump problem! Before servicing the pump carefully check the following: inlet plumbing size is adequate, restrictions and/or air leaks, restricted or worn orifice, operation of unloader valve (if installed in the system), operation of pressure gauge. Ensure that all shut off valves in your system are fully open. Most problems are **not** pump problems but problems with other components in the system!

### USING SOAP

If soap is being run through the pump it is good practice to run water only through the pump for approximately two minutes at the end of the day's washing. This helps to remove any soap from the pump which might otherwise deposit on the valve seats.

### PRESSURE REGULATOR VALVE

X series pumps normally come equipped with a pressure regulator valve. This valve, normally located on the left side of the manifold when facing the front of the pump, can be used to regulate the pump outlet pressure if there is no unloader valve on the pump. In systems with an unloader valve installed, this valve acts as a safety pressure relief valve in case of unloader malfunction.

If plumbing the bypass of the pressure regulator valve back to the inlet of the pump, it is recommended that the bypass be directed to a baffled reservoir tank, with at least one baffle between the bypass line and the inlet of the pump.

Although not recommended, bypass fluid may be returned from the pressure regulator valve back to the inlet of the pump if the system is properly designed to protect your pump. When using this method a pressure reducing valve should be installed between the bypass connection and the inlet of the pump to avoid excessive pressure to the inlet of the pump. It is also recommended that a temperature sensing valve be used in the bypass line to prevent excessive heat build-up. Pressure in the bypass line should be checked initially and periodically to avoid over-pressurizing the inlet.

### PUMP PACKINGS

The X series pumps are packed with a series of durable packings and adapters. As packings wear, some additional adjustment of the gland nut may be necessary. Tighten the gland nut firmly but not excessively. If excessive pressure drop is experienced and other sources of potential pressure drop have been ruled out, the packings may require replacement. When replacing the packings, note the correct order of replacement, as shown in the exploded view diagram on the next page.

---

## SPECIFICATIONS

---

	<b>X8</b>	<b>X10</b>	<b>X20</b>
Plunger Diameter (mm)	22	28	20
Stroke (mm)	15	16	18
GPM output per 100 RPM	0.45	0.75	0.45
Inlet Port (1) (NPT)	1/2	1/2	1/2
Discharge Port (2) (NPT)	3/8	3/8	3/8
Manifold Material	Bronze		
Plunger Material	SS & Ceramic		
Connecting Rod Material	Bronze		
Valve Material	304 SS		
Crankshaft Ball Bearing	1-Row	Double Row	
Crankshaft Material	Chrome Molybdenum		
Crankshaft Diameter (mm)	19	24	24
Crankcase Material	Die-cast Aluminum Alloy		
Pulley Mounting	Either Side		
Crankcase Capacity (liters)	0.75	1	1
Weight (lbs)	23	31	31

# MAGIKIST X-SERIES

TRIPLEX CERAMIC PLUNGER PUMPS

## EXPLODED VIEW MODELS X8 • X10 • X20

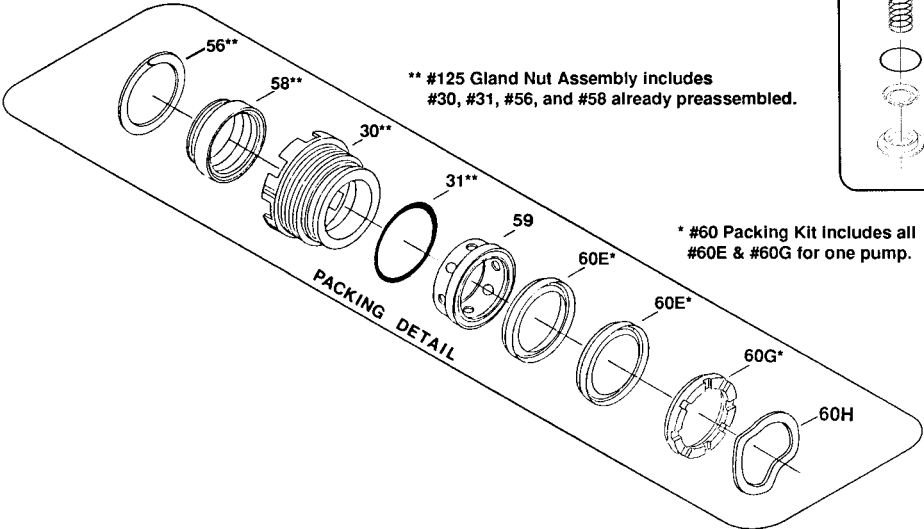
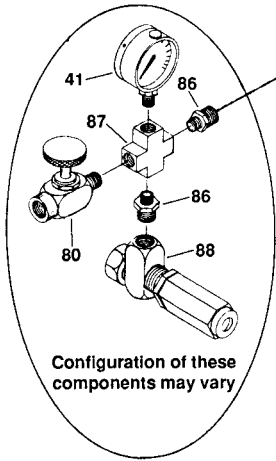
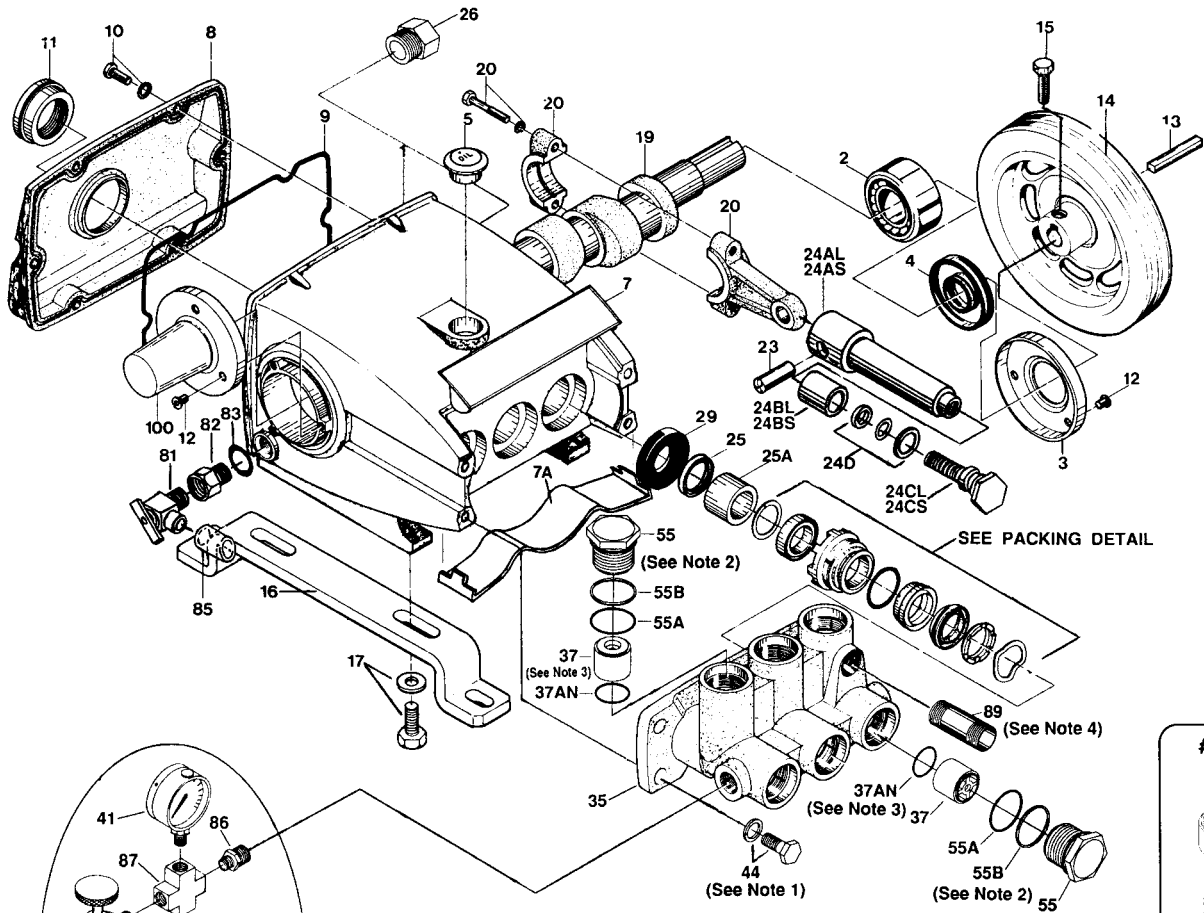

SEE PACKING DETAIL

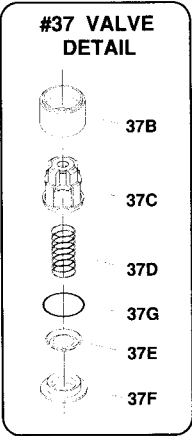

\* #60 Packing Kit includes all #60E & #60G for one pump.

# MAGIKIST X-SERIES

**TRIPLEX CERAMIC PLUNGER PUMPS**

## PARTS LIST

MODELS X8 • X10 • X20

### HOW TO SPECIFY A PART NUMBER

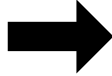

A complete part number consists of the pump model number (X8, X10, or X20) followed by one of the item numbers below. For example X81 refers to the crankcase for the X8 pump, X1037 refers to the valve for the X10 pump, etc. Depending on what options were ordered with your pump some parts shown may not be included with your pump. Parts not applicable to a pump model have a dash in the quantity column.

Item Number	Description	Quantity		
		X8	X10	X20
1	Crankcase	1	1	1
2	Ball Bearing	2	2	2
3	Bearing Cover	2	2	2
4	Crankcase Seal	2	2	2
5	Oil Filler Cap	1	1	1
7	Plunger Cover	1	1	1
7A	Oil Drip Pan	-	1	1
8	Back Cover	1	1	1
9	Back Cover Gasket	1	1	1
10	Back Cover Screw	6	6	6
11	Oil Gauge Window (see note 5)	1	1	1
12	Bearing Cover Screw	6	6	6
13	Pulley Key	1	1	1
14	Pulley (A section)	1	1	1
15	Pulley Set Screw	1	1	1
16	Rail	2	2	2
17	Rail Bolt & Washer	4	4	4
19	Crankshaft	1	1	1
20	Connecting Rod	3	3	3
23	Plunger Pin	3	3	3
24L	Plunger (24AL/BL/CL/D) (2.5" ceramic)	3	3	3
24S	Plunger (24AS/BS/CS/D) (1" ceramic)	3	3	3
24AL	SS Plunger Body (2.5" ceramic)	3	3	3
24AS	SS Plunger Body (1" ceramic)	3	3	3
24BL	Ceramic Plunger Sleeve (2.5" ceramic)	3	3	3
24BS	Ceramic Plunger Sleeve (1" ceramic)	3	3	3
24CL	Plunger Bolt (2.5" ceramic)	3	3	3
24CS	Plunger Bolt (1" ceramic)	3	3	3
24D	Plunger Gasket Set	3	3	3
25	Plunger Wiper	3	3	3
25A	Foam Oiler	3	3	3
26	Oil Drain Plug	1	1	1
27	Crankcase Nut & Washer (see note 1)	4	4	4
29	Plunger Seal	3	3	3
30	Gland Nut	3	3	3

Item Number	Description	Quantity		
		X8	X10	X20
31	Gland Nut O-ring	3	3	3
35	Manifold	1	1	1
37	Valve (see note 3)	6	6	6
37AN	Valve O-ring (see note 3)	6	6	6
37B	Valve Cover	6	6	6
37C	Valve Spring Retainer	6	6	6
37D	Valve Spring	6	6	6
37E	Valve Disc	6	6	6
37F	Valve Seat	6	6	6
37G	Valve Cover O-ring	6	6	6
41	Pressure Gauge	1	1	1
44	Bolt/Washer (see note 1)	4	4	4
50	Crankcase Stud (see note 1)	4	4	4
55	Valve Cap (see note 2)	6	6	6
55A	Valve Cap O-ring	6	6	6
55B	Valve Cap Backing Ring (see note 2)	6	6	6
56	Water Seal Retaining Ring	3	3	3
58	Water Seal	3	3	3
59	Leakage Adapter	3	3	3
60	Packing Kit (includes 60E & 60G)	1	1	1
60E	V-Packing	6	6	3
60G	Bottom Adapter	3	3	3
60H	Wave Spring	3	3	3
80	Needle Valve	1	1	1
81	Oil Drain Cock	1	1	1
82	Adapter	1	1	1
83	Adapter O-ring	1	1	1
85	Oil Drain Hose	1	1	1
86	3/8 x 1/4 Reducing Nipple	2	2	2
87	Cross	1	1	1
88	Pressure Regulator Valve	1	1	1
89	Inlet Nipple (see note 4)	1	1	1
100	Crankshaft Protector	1	1	1
125	Gland Nut Assembly (30/31/56/58)	3	3	3

## NOTES

1. Older pump models used #50 crankcase stud (not pictured) and #27 crankcase nut & washer (not pictured) in place of #44 bolt & washer.
2. #55 valve cap on 1990 and earlier models may not use #55B valve cap backing ring. All #55 valve cap supplied after 1990 require #55A valve cap o-ring and #55B valve cap backing ring.
3. #37AN valve o-ring is used with newer style valves as shown in the exploded view on the previous page. For older style valves (not pictured) use #37A valve o-ring.
4. For pumps supplied on units, #89 inlet nipple may not be used.
5. When ordering #11 oil gauge window specify either new screw-type style (threads on outside of window), or older push-in style (no threads on window).

---

# REPAIR INSTRUCTIONS

---

## VALVE SERVICE

1. Remove any accessories which interfere with the removal of the valve caps (#55). Take care to remember their position so that they may be reinstalled correctly.
2. With a 31 mm socket remove the (six) valve caps (#55). Replace valve cap o-rings (#55A) and valve cap backing rings (#55B) if they are cut, flattened, or otherwise distorted (note that #55 on 1990 and earlier models may not use #55B).
3. Remove the inlet and discharge valves (#37) from the manifold. Inspect valves, checking the seat and disc for any pitting or wear. In addition, check for broken valve springs. Replace valve if necessary.
4. Check valve o-rings (#37AN) and replace if cut or distorted. For older style valves, unlike those shown in the exploded view, always discard the o-rings and replace them with new o-rings (#37A).
5. Insert valves ensuring that they are oriented in the correct manner. Suction valves (top part of manifold) are oriented with the valve seat facing upwards. Discharge valves (front part of manifold) are oriented with the valve seat facing into the front of the manifold. Ensure that valve o-rings are inserted only on the side of the valve that is inserted into the manifold first.
6. Replace the valve caps and torque to 20 foot lbs.

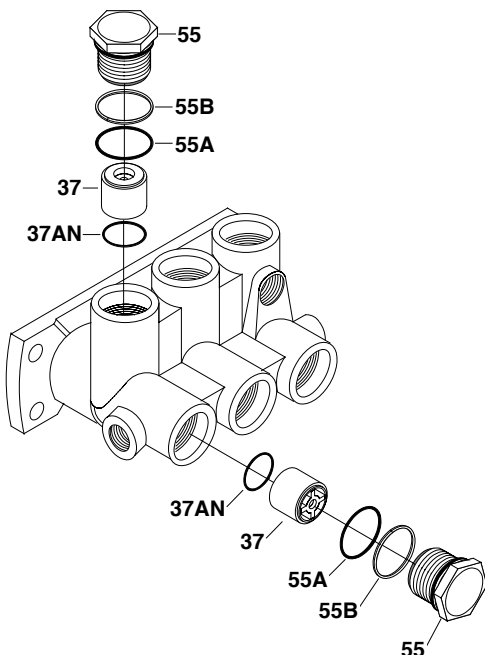

7. Reinstall all accessories previously removed.

## MANIFOLD ASSEMBLY & DISASSEMBLY

1. Remove any accessories such as pressure gauge, pressure regulating valve, unloader, etc. Take care to remember their position so that they may be reinstalled correctly.
2. Remove the oil drip pan (#7A) (X10 and X20 only) and the plunger cover (#7).
3. Use a socket or wrench (12 mm for the X8, 14 mm for the X10 & X20) to remove the four manifold bolts (#44) and pull the manifold (#35) forward. (Note that older pump models used #50 crankcase stud and #27 crankcase nut in place of #44 bolt. For these pumps simply remove the four crankcase nuts from the studs). A rubber mallet may be used to gently tap the manifold forward (be careful not to exert any downward pressure on the manifold). In addition, rotating the pulley by hand may aid in removing the manifold.
4. Remove the gland nuts (#30) using the supplied gland nut tool (note that the small end of the gland nut tool is used for X8 pumps while the large end of the gland nut tool is used for X10 and X20 pumps).
5. Check the condition of the water seals (#58). If the lip of the seal is folded or the seal is worn or torn in any manner then replace the seal by removing the water seal retainer (#56) first. The water seal is press fit into the gland nut and therefore usually needs to be removed from behind with the use of a small screwdriver and hammer. Alternately, the gland nut with water seal installed may be purchased (#125). To insert the water seal into the gland nut you will need a small press. Before inserting the water seal spread a drop of oil around the inside of the gland nut to assist the insertion of the seal. Ensure that the seal is oriented correctly and that it is installed straight. Using excessive force when inserting the seal may damage it. Once the seal is installed in the gland nut replace the retainer, ensuring that it is **fully** inserted into the groove of the gland nut.
6. Check the condition of the gland nut o-rings (#31). If cut or flattened then replace.
7. Use a small screwdriver to remove the leakage adapter (#59), v-packing (#60E), bottom adapter (#60G), and wave spring (#60H). Replace

- 
- v-packings if worn or cut. Replace other parts if worn. Reinsert parts into manifold taking care that they are in the proper order.
8. Reinsert gland nuts and hand tighten only. Dab some water pump grease inside on the packings.
  9. Remove and check the condition of the foam oilers (#25A) and the plunger wipers (#25). Replace if necessary and reinsert in correct order onto plungers.
  10. Check condition of plungers. Replace ceramic sleeve if chipped or cracked by removing plunger bolt using a 19 mm socket for the X8, a 22 mm socket for the X10, or a 14 mm socket for the X20. Because thread lock is used on the plunger bolt the entire plunger may have to be removed in order to remove the plunger bolt. In this case refer to the Drive-end Service section. With plunger bolt off replace plunger bolt gasket set. Reinstall ceramic sleeve and plunger bolt using thread lock on the threads of plunger bolt. Torque to 20 foot lbs. For replacement of plunger body see Drive-end Service section.
  11. Reinstall the manifold by inserting one plunger at a time into each water seal. **Be very careful that the lips of the water seal do not fold under.** Push the manifold back fully over the plungers. If the manifold does not push back easily you may have to loosen the gland nuts or rotate the pulley by hand.
  12. Once the manifold is reinstalled back on the crankcase reinstall the bolts and washers through the manifold and into the crankcase. (For older pump models reinstall the nuts & washers onto the crankcase studs). Torque the bolts to 15 foot lbs.
  13. Use the gland nut tool to tighten the gland nuts up tight.
  14. Oil each foam oiler and replace the oil drip pan (X10 and X20 only) and plunger cover.
  15. Reinstall all the accessories previously removed.
- DRIVE-END ASSEMBLY & DISASSEMBLY**
1. Remove the manifold as described under Manifold Service.
  2. Drain crankcase oil using the oil drain cock (#81).
  3. Loosen the pulley set screw (#15) and remove the pulley (#14) and the pulley key (#13). Be careful not to damage the pulley in any way.
  4. Loosen the bearing cover screws (#12) and remove the bearing cover (#3) and the crankshaft protector (#100).
  5. Remove the back cover screws (#10). Remove the back cover (#8) and the back cover gasket (#9). Replace the gasket if cut or flattened.
  6. Loosen bolts on the connecting rods (#20) and remove the end-caps. **End-caps of connecting rods must not be mixed up and must be reinstalled in the same orientation.**
  7. Push plungers all the way forward so that crankshaft is free.
  8. Use a mallet to gently tap crankshaft straight out one side of the crankcase. Be careful that the connecting rods do not interfere with removal of crankshaft. If the bearing on the side of the crankcase opposite to which the crankshaft is being removed remains on the crankshaft, be very careful when moving it through the opposite side of the crankcase. It should move straight through the crankcase without marking the crankcase.
  9. If bearings remain on crankshaft a press may be required to remove them. Inspect bearings and replace if necessary. Install bearings fully onto crankshaft. Be careful not to exert any force on outer track of bearing.
  10. Remove plungers, plunger pins, and connecting rods. Inspect for any bending, cracks or wear. Check to ensure that there is no play between connecting rod, pin, and plunger. Note that plunger pins are staked.
  11. Check plunger seals for wear or cuts. Replace if necessary.
  12. Reinsert plungers, plunger pins, and connecting rods (without end-caps). Push plungers all the way forward.
  13. Reinsert crankshaft into crankcase. Gently tap crankshaft and bearings into place such that crankshaft is centered in crankcase. Lubricate bearings and crankshaft throws with a light film of oil.
  14. Reinstall end-caps on connecting rods. Torque bolts to 7.5 foot lbs. Ensure crankshaft turns freely.
  15. Check crankshaft seals and replace if cut, worn, or distorted. Place over end of crankshaft and gently tap into place. Be careful that you do not cut the seal on the crankshaft keyway.
-

- 
- |  |  |
|--|--|
| 16. Replace bearing cover and crankshaft protector with bearing cover screws. Hand tighten with screwdriver. | in the installation of the pulley. Be careful not to damage the pulley in any way. Hand tighten the pulley set screw. Ensure pulley is secure on the crankshaft. |
| 17. Replace back cover and back cover gasket with back cover screws. Hand tighten with screwdriver.          | 19. Fill crankcase with recommended oil to halfway mark of oil gauge window.   |
| 18. Replace pulley and pulley key. You may wish to spread a drop of oil on the crankshaft end to aid         | 20. Replace manifold as described under Manifold Service section.  |
- 

## WARRANTY

Magikist X-Series pumps are warranted by the manufacturer to be free from defects in material and workmanship for one year from date of manufacturer's shipment, provided the equipment is installed and operated in accordance with factory recommendations and instructions. This warranty is limited to repairing or replacing products which manufacturer's investigation shows were defective at the time of shipment by the manufacturer. This warranty does not cover normal wear, nor does it cover damage caused by neglect, misuse, accident, faulty installation or tampering in a manner to impair its normal operation. All products subject to this warranty shall be returned **freight prepaid** to Magikist Ltd., Winnipeg, Canada for examination, repair, or replacement.

The express warranty set forth herein is in lieu of all other warranties, express or implied, including without limitation any warranties or merchantability or fitness for a particular purpose and all such warranties are hereby disclaimed and excluded by the manufacturer. Repair or replacement of defective products as provided is the sole and exclusive remedy provided hereunder and the manufacturer shall not be liable for any further loss, damages or expenses, including incidental and consequential damages, directly or indirectly arising from the sale or use of this product.

This warranty is subject to the installation and operating conditions as described in this manual. This warranty does not apply to optional equipment which may have been supplied with your pump. Refer to the warranty supplied with the optional equipment for information on that equipment's warranty.

Parts originally manufactured by Magikist Ltd. must be used or this limited warranty will be voided. Magikist Ltd. will be absolved of any liability if parts other than Magikist Ltd. manufactured parts are used.

There are no warranties which extend beyond the description of the face thereof.